



Electric four wheel counterbalance forklift truck

CBH 2.0-3.0

Lift height: 3300-4800 mm / Load capacity: 2000-3000 kg



CBH 2.0-3.0

Trucks that simply work.

Built for use in changing environments.

The AntOn by Jungheinrich CBH electric forklift truck combines what counts for daily operation: robust technology, easy handling and reliable performance.

Whether in the warehouse, outdoors or at the loading ramp: the CBH is versatile and delivers exactly where it is needed. This electric forklift truck will always make your job easier – from internal transport, manoeuvrable applications in confined spaces and the rapid loading and unloading of HGVs.

It excels not only in daily use but also through its fast availability and a price/performance ratio that makes transitioning to electromobility particularly appealing.

With three carefully designed equipment variants and advanced lithium-ion power, the CBH offers exactly the flexibility your company needs today, making the choice easy – a forklift truck that simply works.

All benefits at a glance

- Reliable technology for everyday use.
- Three equipment variants for a wide range of requirements.
- Simple operation for comfortable handling.
- Lithium-ion technology for fast charging and consistent performance.
- High availability for fast delivery.

Versatile

Functional power for every job.

- Two capacity options, each available in three equipment variants to match different applications, needs and budgets.
- Compact and highly manoeuvrable – even in tight spaces.
- Large tyres and high ground clearance for outdoor use on uneven ground.
- Flexible charging options via an external or built-in charger, depending on the model.
- Travel speeds up to 17 km/h for more efficient working.

Straightforward

Intuitive technology that makes work easier.

- LED display with all key info at a glance.
- Simple control elements – from the control panel and comfortable pedal to the water-resistant charging port.
- Optimum visibility for safer daily operation.
- Ergonomic operator position with adjustable steering wheel and, depending on the variant, comfort seat and generous legroom.

Cost-effective

Solutions for every task and every budget.

- Maintenance-free 80-V lithium-ion battery for long service life and short charging pauses.
- Rapid lift speeds save time with every application.
- High availability and cost-efficient acquisition.
- Fast spare parts supply keeps your operations running smoothly.

Masts

CBH 2.0 (V1: ZT3300, ISS, ZH1), CBH 2.5 (V1: ZT3300, ISS, ZH1)	Lift (h3)	Retracted mast height (h1)	Free lift (h2)	Extended mast height (h4)	Forward/backward tilt of fork carriage
Duplex mast ZT	3300 mm	2240 mm	195 mm	4360 mm	6 / 10 °
CBH 2.0 (V2: DZ4800, ISS, ZH2, Eco1), CBH 2.0 (V3: DZ4800, ASS, ZH2, Com3)	Lift (h3)	Retracted mast height (h1)	Free lift (h2)	Extended mast height (h4)	Forward/backward tilt of fork carriage
Triplex mast DZ	4800 mm	2265 mm	1240 mm	5855 mm	6 / 6 °
CBH 2.5 (V2: DZ4800, ISS, ZH2, Eco1), CBH 2.5 (V3: DZ4800, ASS, ZH2, Com3)	Lift (h3)	Retracted mast height (h1)	Free lift (h2)	Extended mast height (h4)	Forward/backward tilt of fork carriage
Triplex mast DZ	4800 mm	2265 mm	1240 mm	5895 mm	6 / 6 °
CBH 3.0 (V1: ZT3300, ISS, ZH1)	Lift (h3)	Retracted mast height (h1)	Free lift (h2)	Extended mast height (h4)	Forward/backward tilt of fork carriage
Duplex mast ZT	3300 mm	2215 mm	135 mm	4430 mm	6 / 10 °
CBH 3.0 (V2: DZ4800, ISS, ZH2, Eco1), CBH 3.0 (V3: DZ4800, ASS, ZH2, Com3)	Lift (h3)	Retracted mast height (h1)	Free lift (h2)	Extended mast height (h4)	Forward/backward tilt of fork carriage
Triplex mast DZ	4800 mm	2265 mm	1170 mm	5975 mm	6 / 6 °

VDI table

Characteristic	1.1	Manufacturer (abbreviated description)		Jungheinrich		
	1.3	Drive type		electric		
	1.4	Operation		Seat		
	1.5	Load capacity/load	Q kg	2000	2500	3000
	1.6	Load centre distance	c mm	500		
	1.8	Load distance, centre of drive axle to fork	x mm	495		481
	1.9	Wheelbase	y mm	1540	1740	
Weights	2.1.1	Service weight (incl. battery)	kg	3549	3977	4335
	2.2	Axle load laden front/rear	kg	4930 / 619	5795 / 682	6575 / 760
	2.3	Axle load unladen front/rear	kg	1635 / 1909	1865 / 2112	1880 / 2455
Wheels/chassis	3.1	Tyres		Super-elastic (SE)		
	3.2	Tyre size, front		7.00-12		28x9-15
	3.3	Tyre size, rear		18x7-8		200/50-10
	3.5	Wheels, number front/back (x=driven)		2x / 2		
	3.6	Tread width, front	b10 mm	975		1010
	3.7	Tread width, rear	b11 mm	955		
	Basic dimensions	4.1	Forward/backward tilt of mast	a/β °	6 / 10	
4.2		Retracted mast height (h1)	h1 mm	2090		2070
4.3		Free lift (h2)	h2 mm	120		135
4.4		Lift (h3)	h3 mm	3000		
4.5		Extended mast height (h4)	h4 mm	4025		4095
4.7		Height of overhead guard (cab)	h6 mm	2165		2180
4.8		Seat height/stand height	h7 mm	1095		1110
4.12		Coupling height	h10 mm	310	311	307
4.19		Total length	l1 mm	3535	3695	3712
4.20		Length including fork shank	l2 mm	2385	2545	2562
4.21.1		total width	b1 mm	1154		1210
4.22		Fork dimensions	s/e/ l mm	40 x 122 x 1150		45 x 122 x 1150
4.23		Fork carriage connection class		2A		3A
4.24		Fork carriage width	b3 mm	1040		1100
4.31		Ground clearance laden under mast	m1 mm	125		130
4.32		Ground clearance centre of wheelbase	m2 mm	150	170	185
4.34.1		Aisle width (pallet 1000x1200 sideways)	Ast mm	3824	3995	4060
4.34.2		Aisle width (pallet 800x1200 length)	Ast mm	4024	4195	4260
4.35		Turning radius	Wa mm	2129	2300	2379
4.36		Smallest pivot point distance	b13 mm	662	838	
Performance data	5.1	Travel speed laden/unladen	km/h	14 / 15	16 / 17	
	5.2	Lift speed laden/unladen	m/s	0.4 / 0.41	0.5 / 0.56	0.42 / 0.5
	5.3	Lowering speed laden/unladen	m/s	0.54 / 0.56		0.43 / 0.44
	5.5	Drawbar pull laden/unladen	N	2090 / 2090	2270 / 2270	2770 / 2770
	5.6	Max. drawbar pull laden/unladen	N	12570 / 12570	13760 / 13760	16280 / 16280
	5.7	Gradeability laden/unladen	%	7 / 14	14 / 25	12 / 23
	5.8	Max. gradeability laden/unladen	%	15 / 20	20 / 25	
	5.9	Acceleration time laden/unladen	s	7.9 / 7.5	6.6 / 6.4	6.7 / 6.3
	5.10	Service brake		hydraulic		

Electric motor/electronics	6.1	Drive motor, performance S2 60 min	kW	10	17		
	6.2	Lift motor, performance with S3	kW	16	26		
	6.4	Battery voltage/nominal capacity	V / Ah	80 / 230			
	6.6.1	Energy consumption according to EN cycle	kWh/h	6.77	7.1	10.73	
	6.6.2	CO2 equivalent according to EN ISO 23308	kg/h0	3.7	3.8	5.8	
	6.7	Throughput	t/h	116	150	180	
	6.8.1	Energy consumption with max. throughput	kWh/h	5.88	6.21	10.01	
	Other	8.1	Type of drive control		AC		
10.1		Operating pressure for attachment	bar	180			
10.2		Oil flow for attachments	l/min	35			
10.7		Sound pressure level according to EN12053	dB (A)	74			
<p>- This data sheet according to VDI guideline 2198 only states the technical values of the standard truck. Different tyres, other masts, additional equipment etc. may result in different values.</p>							

Appendix

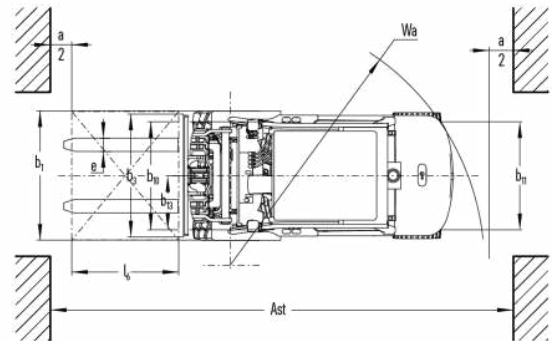
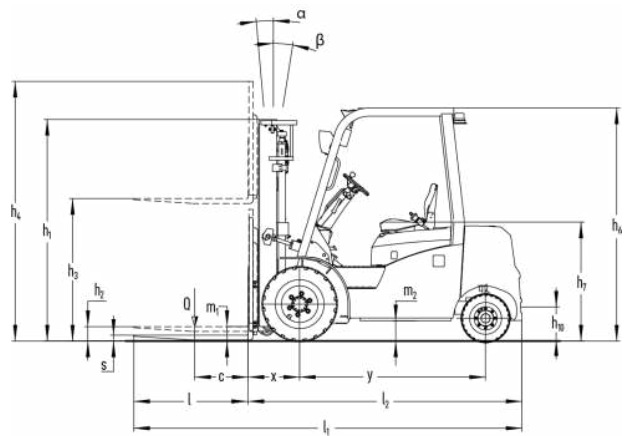
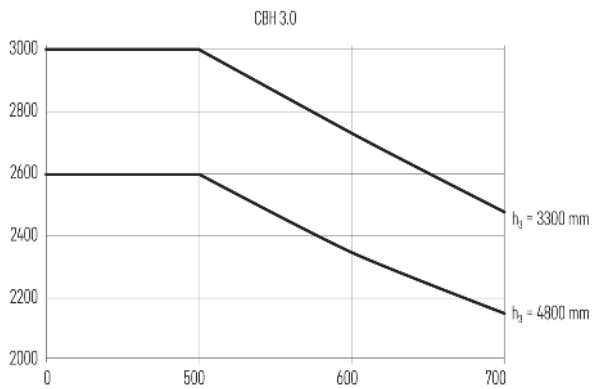
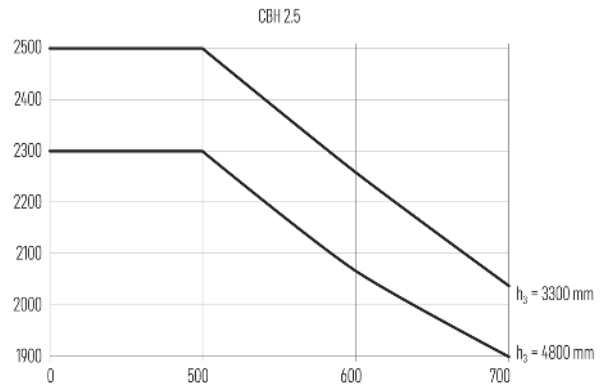
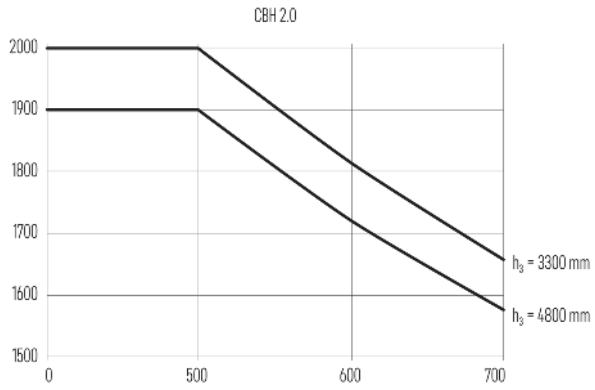

The German production facilities in
Norderstedt, Moosburg and Landsberg are
certified as well as our Genuine Parts
Center in Kaltenkirchen.

ISO 9001
ISO 14001

Jungheinrich fork lift trucks meet European
safety requirements.



anton
BY JUNGHEINRICH